



Bumpstop Assembly and use instructions

Optional free standing large sub plate

- 1 : For the best stability please detach the 2 rails fixed to your Bumpstop frame base.
- 2 : Turn the bars through 90deg to the frame and using the same fixings screw the legs onto the Bumpstop as shown below using the **outermost holes** at each end of the frame. (Maximum stability.)

Cups removed for clarity.

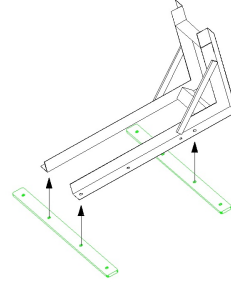

- 3 : Now fix the feet to the floor or use the 4 rubber feet (pushed through underside of the 2 cross bars between the bar and the floor.

the **outermost holes**) on the

General notes :

Used under normal conditions your quality British manufactured Bumpstop product should provide many years of happy ownership and service.

- Screw Fixing to the surface where the Bumpstop is used is essential if the optional bars are not fitted and always recommended. The Bumpstop may be used free standing on level surfaces (with optional free standing large sub plate).
- Normal usage is to push the motorcycle forwards into the lead cup and continue pushing until the bike is firmly nested in both the front and rear cups. The motorcycle will now be free standing.
- Removal is the reverse, just pull the motorcycle backwards.
- If the motorcycle is reversed into the Bumpstop you may wish to consider purchasing one or a pair of our larger cups for stability and ease of use.
- **Adjustment.** Adjust the lead cup by removing the pin fixing and moving the pin to the hole that best suits your needs.

For smaller wheels a scooter version is available.

- Rough guide :**
- Hole 1** 14 - 17" diameter wheels,
 - Hole 2** 16 - 19" (standard use.)
 - Hole 3** 19 - 20" **And rear cup** (when purchased)
 - Hole 4** 21" + diameter **and rear cup**.(when purchased).

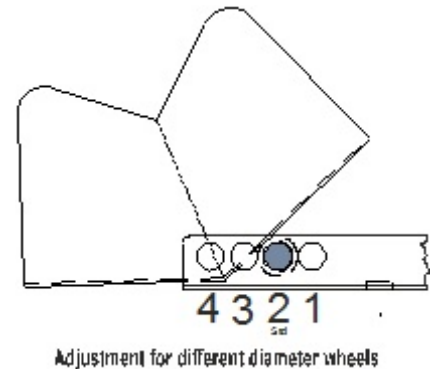

Thatcham Security - (Thatcham version only).

When used in conjunction with a Thatcham approved quality chain and padlock the unit becomes a security device. Place the chain through the wheel and then through the tube provided. The unit must be bolted down directly to a concrete floor or similar for maximum security. Use the security bolts provided for maximum protection. When bolting down ensure the Rawl bolt expands securely in the fixing. **(Thatcham approved lock and chain available - see website)**

Transporting a motorcycle.

If using the Bumpstop free standing then place against a bulkhead or something where the Bumpstop can not slide forward in the event of the vehicle braking hard.

We do advise screwing to the floor wherever possible.

The motorcycle should be secured by other means before driving off. **Bumpstop.co.uk have devised a handlebar strap kit for this very purpose which is simple and quick to use. Please see website for details.**

This Bumpstop unit is designed to take most normal motorcycles and larger wheeled scooters. If in doubt please contact sales@Bumpstop.co.uk or our technical dept on 01604 845050.

We hope you enjoy using this product but if you have any concerns please contact us. Thank you for buying one of our **British** made products.

Bumpstop.co.uk